

THIS DRAWING IS UNPUBLISHED. RELEASED FOR PUBLICATION
 © COPYRIGHT BY TYCO ELECTRONICS CORPORATION. ALL INTERNATIONAL RIGHTS RESERVED.

LOC	DIST	REVISIONS			
P	LTR	DESCRIPTION	DATE	DWN	APVD
G	14	F3	REVISED PER ECR-08-022232	06OCT08	HMR TM

AMP PART NUMBER	PACKAGE TYPE	QTY
8-35187-3	LOOSE PIECE, BOX	25
8-35187-5	LOOSE PIECE, BOX	500

AMP
WIRE RANGE

2 AWG
SOLID OR STRANDED

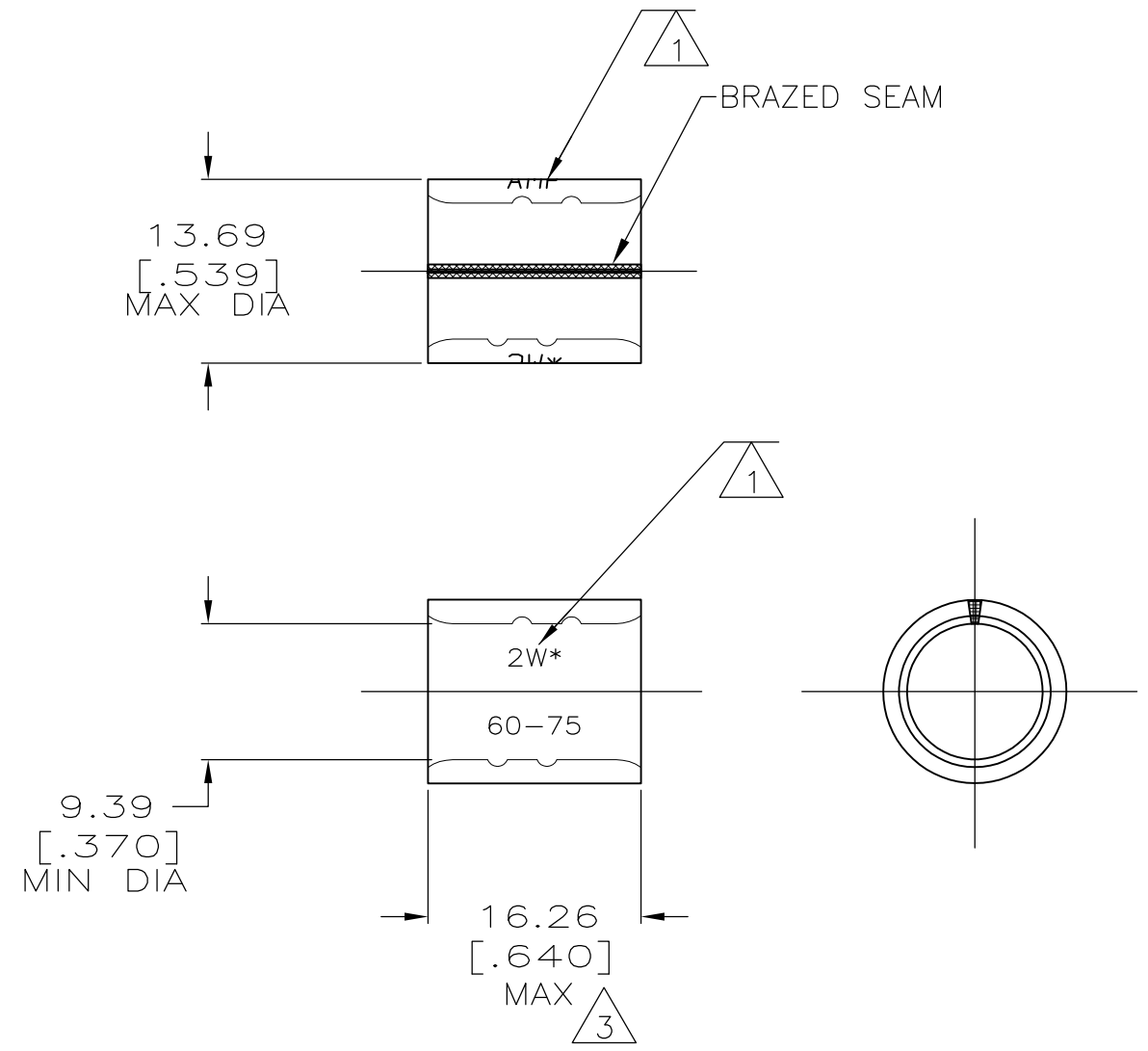

- 1 STAMP AMP 2W* 60-75 APPROX AS SHOWN
- 2 MATERIAL THK: 1.78^{±0.08} [.070^{±.003}]
- 3 MAX LENGTH DOES NOT INCLUDE MANUFACTURING TABS.
- 4 TIN PLATE 0.00254 [.000100] MIN THK PER ASTM B545
- 5 TIN/LEAD (60/40) PLATE, 0.00254 [.000100] MIN THK PER SAE-AMS-P-81728
- 6 UL LISTED E13288, 2 AWG STRANDED
- 7 PRELIMINARY - NOT FOR PRODUCTION
- 8 CSA CERTIFIED LR7189, 2 AWG SOLID OR STRANDED

6 8	4	8-35187-5
6 8	4	8-35187-3
---	5	35187-1
6 8	4	35187
APPROVALS	FINISH	PART NO

AMP INCORPORATED CUSTOMER SERVICE SYSTEMS		MAX RECOMMENDED OPERATING TEMPERATURE: 170° C	THIS DRAWING IS A CONTROLLED DOCUMENT.		DWN DK SCHRUM 8/28/92	Tyco Electronics Corporation Harrisburg, PA 17105-3608	
FOR ADDITIONAL PRODUCT INFORMATION OR COPIES OF DRAWINGS AND TECHNICAL DOCUMENTS	PRODUCT INFORMATION CENTER 1-800-522-6752	VOLTAGE RATING: N/A	DIMENSIONS: mm [INCHES]	TOLERANCES UNLESS OTHERWISE SPECIFIED:	CHK DA PATTERSON 9/8/92	NAME SPLICE, PARALLEL, SOLISTRAND	
FOR APPLICATION TOOLING INFORMATION	TOOLING ASSISTANCE CENTER 1-800-722-1111	CIRCULAR MIL AREA: 26.7-42.4mm² [52,600-83,700] SOLID OR STRANDED		0 PLC ± - 1 PLC ± - 2 PLC ± 0.20[.008] 3 PLC ± - 4 PLC ANGLES ± -	APVD DA PATTERSON 9/8/92	PRODUCT SPEC	RESTRICTED TO
FOR ORDER ENTRY	1-800-526-5142	THIS DRAWING IS A CONTROLLED DOCUMENT FOR AMP INCORPORATED. IT IS SUBJECT TO CHANGE AND THE CONTROLLING ENGINEERING ORGANIZATION SHOULD BE CONTACTED FOR THE LATEST REVISION.	MATERIAL COPPER ASTM B-152	FINISH SEE TABLE	APPLICATION SPEC	WEIGHT	SIZE A3
					CUSTOMER DRAWING	CAGE CODE 00779	DRAWING NO C-35187
					SCALE 2:1	SHEET 1 OF 1	REV F3